

CL Series Intelligent Counting(Length)/ Frequency(Linespeed) Meter Operation Manual



Features

- ⊙ Two inputs, one for counting (length), the other for frequency (linespeed).
- ⊙ Counting and frequency coefficient can be set separately.
- ⊙ 2 counting alarm outputs, one frequency alarm output.
- ⊙ Counting speed 1CPS/30CPS/1KCPS/10KCPS.
- ⊙ Counting coefficient range: 0.00001~999999.
- ⊙ Power fail memory function.
- ⊙ 4 kinds of input modes, 8 kinds of output modes.
- ⊙ 3 alarm outputs.
- ⊙ Rotary encoder doesn't need pull-up resistor.
- ⊙ Optional RS485 communication port(MODBUS-RTU communication protocol).
- ⊙ Can be Widely applied to slide fastener machine, foodstuff machine, packing machine, etc.

I. Model Illustration

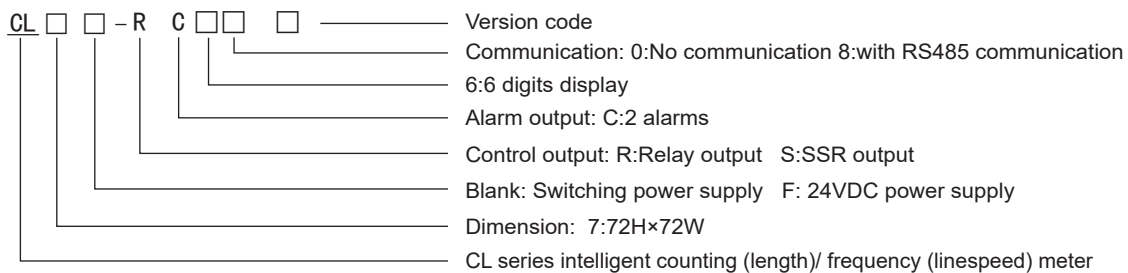

II. Ordering code

No.	Model	Dimension(mm)	Function			
			Digit	Linespeed output	Counting/length counting output	Communication
1	CL7-RC60	72H×72W	6	1 relay	2 relay output	No
2	CL7-RC68	72H×72W	6	1 relay	2 relay output	Yes

III. Technical Specification

Power	Power: AC/DC 100~240V 50/60Hz
	Power consumption<5W
Trigger edge	Rising edge, Falling edge
Data reserve	10 years
Input signal (sine wave, square wave)	Electrical level: High:3~30V Low:0~2V
Counting speed	≤10Kcps
Counting range	-199999~999999
Frequency range	0.1~10000Hz
Frequency measuring accuracy	±0.1%±3digits
Output delay time	0000.01~9999.99S
Counting output mode	F、N、C、R、K、P、Q、A optional(rising or falling counting)
Input impedance	5.4kΩ
Communication	Communication port: RS485
	Communication protocol: MODBUS-RTU
Anti-interference ability	Power:4000Vp-p I/O terminal:2000Vp-p
Withstand Voltage	AC 1.5KV 1min(Power terminals & terminals for external connection)
Relay contact capacity	AC 250V 3A (Resistance loading)
Insulation resistance	≥20MΩ
Environment temperature	-15℃~50℃
Dimension (mm)	Refer to page 6

IV. Panel Illustration

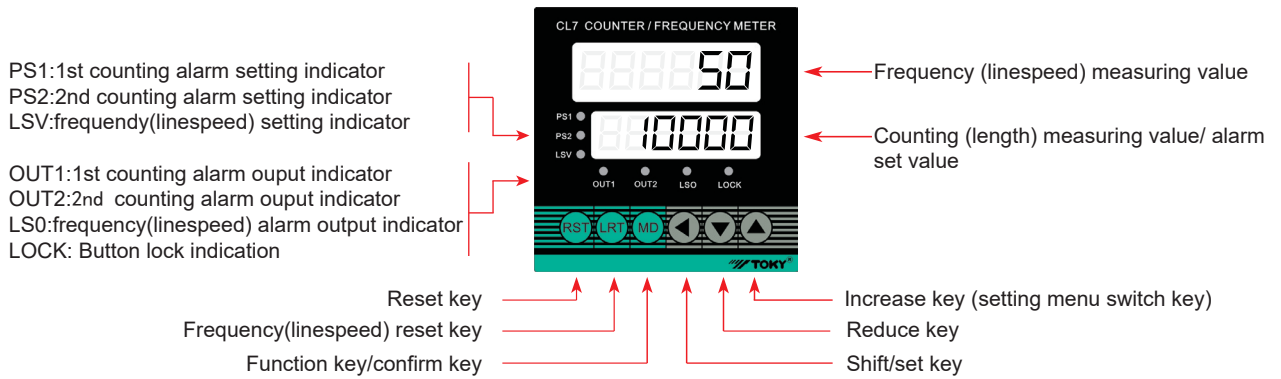

V. Keyboard operating illustration

- Before using the meter, check the connection drawing is right or not, power supply meets the meter's requirement, confirm it correctly and then power it on.
- The meter has 6 operating keys.
 - MD : Setting key: In measuring status, press "MD" 3 seconds, enter into setting status.
 - ▲: Increase key: In setting status, press it once, setting digit add 1; in menu operation, press it to switch the function.
 - ▼: Decrease key: In setting status, press it once, setting digit minus 1.
 - RST : Reset key: In measuring status, press to reset the measuring value; in modifying set value status, press it to move decimal point to the right.
 - ◀: Shift key: In measuring status, press it to enter into modifying set value status; in setting status, press it to move flicker to right.
 - LRT : Linespeed reset key: Press it to reset linespeed measuring value and linespeed output.
- In setting status, press MD key 3 seconds to exit setting status and enter into measuring status; besides, in setting status, if the user doesn't operate the meter for long time, it will exit setting status automatically and enter into measuring status, but the modified value before exit won't be saved.

VI. Operation

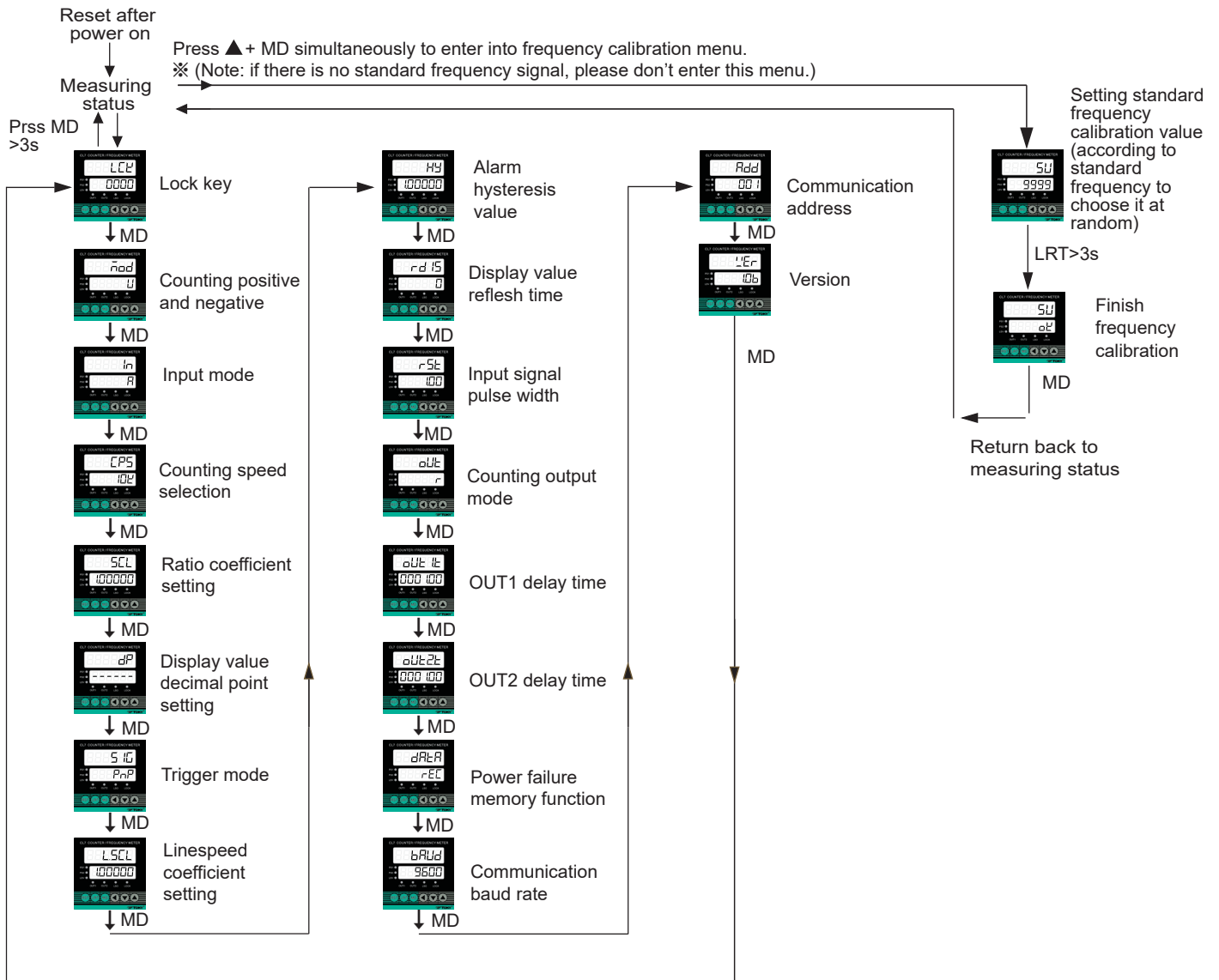

Table 1: Parameters setting illustration

No.	Code	Meaning	Illustration
1	LCK	Key lock	<p>◀ key: shift the flickering digit ▲ key: modify the value of flickering digit Password setting range: 0000~9999 The system locks or unlocks four different functions based on the four values entered by the user.</p> <p>1: Lock or activate the SV value, only when LCK = 0001, SV value can not be changed, otherwise the SV value can be changed; 2: Lock or activate RST, LRT keys, only when LCK=1000, RST, LRT keys are locked, that means pressing RST or LRT key can't reset data. Otherwise, RST, LRT keys' reset function is activated, (RST, LRT external control terminals are not locked) 3: Lock or activate the factory value written function. Only when LCK=0100, in the measuring status, keep pressing the ◀ + ▲ key for 3 seconds to flash "INIT", 1 second later the factory value is restored. 4: Lock or unlock the menu; only when LCK=0010, lock the menu, the user can not modify the menu value; otherwise, if it is not 1, the user can set the value of each menu.</p>
2	nod	Up/down counting mode	"▲": U↔d U: forward counting d: backward counting
3	In	Input mode	<p>Use "▲" key to choose input mode, total 4 types: (refer to Attached A: input mode logic relation chart)</p> <p>A: Counting when INA is high-level, INB is invalid B: INA counts backward when INB is high-level; INA counts forward when INB is low-level. C: INA counts forward; INB counts backward. D: INA phase is ahead of INB, INA counts forward; INA phase is behind INB, INA counts backwards. (For rotary encoder input, no need to connect pull-up resistor, NPN only).</p>
4	CPS	Counting speed	Use "▲" key to choose different counting speed 1→30→1K→10K→
5	SCL	Ratio coefficient	<p>◀ key: shift the flickering digit ▲ key: modify the value of flickering digit Ratio coefficient setting range: 0.00001~999999 Ratio coefficient value: Use the counting input of a pulse to measure the actual value of length, position, or flow.</p>
6	dp	Display value decimal point setting	Use "▲" key to choose different decimal point position
7	SI	Trigger mode	Use "▲" key to choose rising edge or falling edge triggering, choose voltage (NPN) or non voltage (PNP) input
8	LSCL	Linespeed coefficient setting	<p>◀ key: shift flickering digit ▲ key: modify the value of flickering digit Ratio coefficient set range: 0.00001~999999</p>
9	HY	Alarm hysteresis value	<p>Alarm hysteresis value setting: ▲ key: modify the value of flickering digit ◀ key: shift flickering digit RST key: modify hysteresis value decimal point position</p>
10	rd 15	Display value refresh time	<p>Display value refresh time setting, press ▲ key to choose</p> <p>0: refresh automatically 5: refresh 1 time/ 5S; 0.5: refresh 1 time/0.5S; 10: refresh 1 time/ 10S; 1: refresh 1 tim/ 1S; 20: refresh 1 time/ 20S; 2: refresh 1 time/ 2S</p>
11	rSt	Input signal pulse width	<p>Use "▲" key to choose different timing range 1→10→100→1000→ Setting range: 1~1000; Unit: ms Set input signal, like:RESET signal, LRT、RESET signal and PAUSE signal width</p>
12	out	Counting output mode	Press "▲" key to choose different output control mode F、N、R、C、K、P、Q、A, (refer to Attached B: Counter output action mode)
13	out 1t out 2t	OUT1/2 delay time	<p>◀ key: shift flickering digit ▲ key: modify the value of flickering digit. Delay time range: 0.01~9999.99 second</p>
14	dARA	Power failure memory function	<p>REC: memory holding function (memorize measuring data, repower on after power failure, counting and timing will be continued based on previous data. CLRE: no memory holding function, after repower on, previous measuring data will be cleared.</p>
15	baud	Communication baud rate	Communication baud rate: 4800bps or 9600bps for option
16	Addr	Communication address	<p>◀ key: shift flickering digit ▲ key: modify the value of flickering digit. Address setting range: 1~255</p>
17	VER	Version	Current software version

Table 2: SV value setting parameter

No.	Code	Meaning	Illustration	Setting range
1	PS1	Set value 1 (PS1 light on, it displays.)	Up mode, when measuring value rises to set value PS1, OUT1 outputs, OUT1 light is on, reset status is 0. Down mode, when measuring value drops to 0, OUT1 outputs, OUT1 light is on, reset status is PS1. “▲” key: modify value of flickering digit “◀” key: shift flickering digit MD key: confirm modified value. If the value is set as “0” accidentally, press MD key will make it display “Error” or “Erro” for a while, and cannot exit current status. RST key: decimal point shift key, press it to shift the decimal point to the right.	0.00001-999999 (6 digits display)
2	PS2	Set value 2 (PS2 light on, it displays.)	Up mode, when measuring value rises to set value PS2, OUT2 outputs, OUT2 light is on. Down mode, when measuring value drops set value PS2, it=PS1-PS2, OUT2 outputs, OUT2 light is on. MD key, RST key are same as above.	PS1 ≥ SCL PS2 ≥ SCL SCL > 0
3	LSV	Linespeed set value (LSV light on, it displays.)	Up mode, when measuring value rises to set value LSV, LSO outputs, LSO light is on. Down mode, when measuring value drops to set value LSV, LSO outputs, LSO light is on. MD key, RST keys are same as above.	LSV ≥ L.SCL L.SCL ≥ 0

Attached A: Input mode logic relation chart

Mode	UP	down	Illustration
A			INA: counting input INB: not used
B			UP mode: INB no signal input, INA increase counting INB has signal input, INA decrease counting down mode: INB no signal input, INA increase counting INB has signal input, INA decrease counting
C			Up mode: INA increase counting, INB decrease counting display value=INA-INB Down mode: INA decrease counting, INB increase counting display value=INB-INA
D			Up mode: INB lags behind INA, INB increase counting INB leads INA, INB decrease counting Down mode: INB lags behind INA, INB decrease counting INB leads INA, INB increase counting

Attached B: Counter output action mode

		Input mode		Action after counting to set value
		Up timing counting	Down timing counting	
Output mode	F			Display value keep increasing/decreasing, output will continue till the reset input.
	N			Output and display value continue till reset input.

Output mode	C			<p>Display value returns to initial status automatically .</p> <p>Output delays to set time, it returns back to initial status automatically (Output action is repeated single output)</p>
	R			<p>Display value and output delay to set time, they return back to initial status automatically (Output action is repeated single output)</p>
	K			<p>Display value continues to increase/ decrease, till reset input; output delays to set time, then it returns back to initial status. (Output action is single output)</p>
	P			<p>Display value maintains single output delay time, then it displays next cycle value. (In delay time, display value starts next cycle counting/timing from initial value. Output action is repeated single output)</p>
	Q			<p>In single output(delay) time, display value continues to increase/decrease; after single output(delay) time, it returns back to initial status. Output delays to set time, then it returns back to initial status.(Output action is repeated single output)</p>
	A			<p>Minimum set value and OUT2 output continue till manual reset input; OUT1 output delays to set time, then it returns back to initial status. (Output action is single output)</p>

VII. Input connection

1. Input logic: no voltage input(NPN)

(1) Solid state input

- Standard sensor: NPN output type sensor

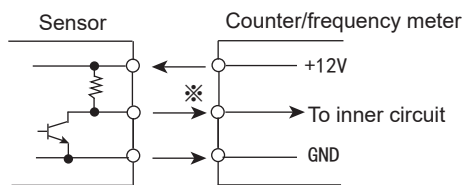

(2) Passive switch signal input

- Switch signal: switch signal connection when meter is set as NPN mode

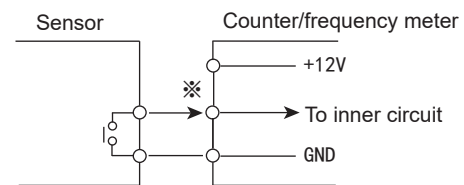

Counting speed should be set as 1 or 30cps

2. Input logic: voltage input(PNP)

(1) Solid state input

- Standard sensor: PNP output type sensor

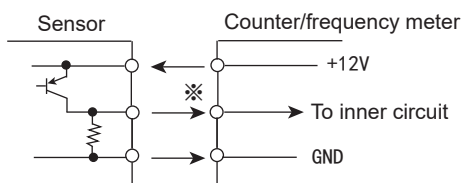

(2) Passive switch signal input

- Switch signal: switch signal connection when meter is set as PNP mode

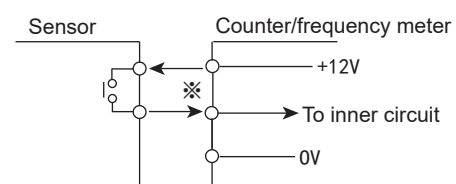

Counting speed should be set as 1 or 30cps

VIII. Connection

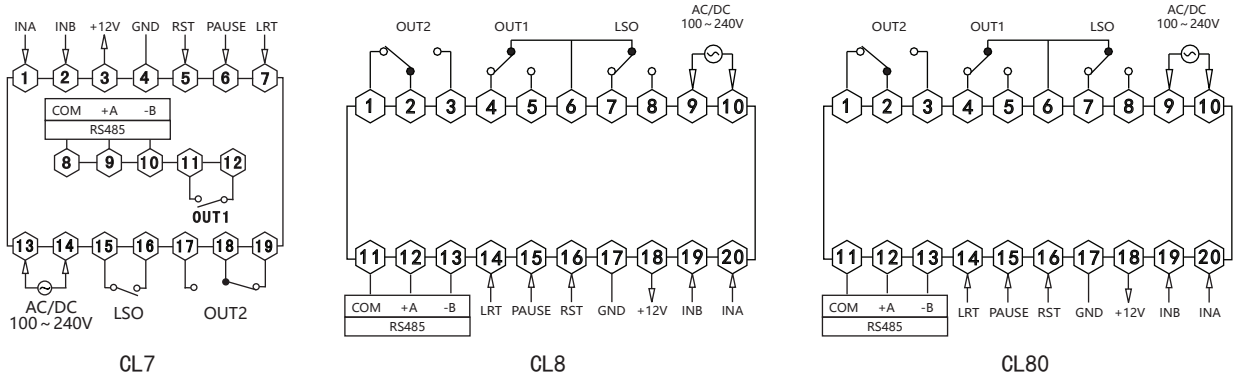

Note: please subject to the diagram on the product if any changes.

IX. Dimension (unit:mm)

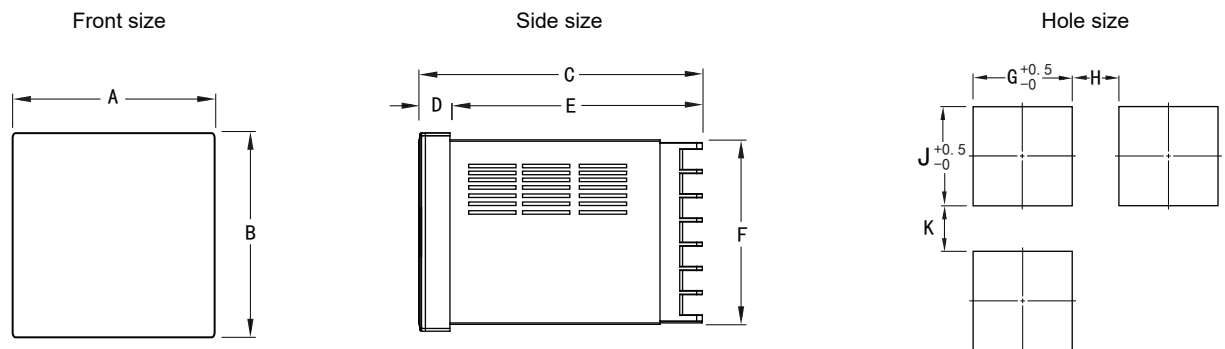

Panel size	A	B	C	D	E	F	G	H(Min)	J	K(Min)
72*72	72	72	97.5	3	94.5	67	67.5	25	67.5	25
48*96	96	48	97.5	3	94.5	44.5	90	25	45	25
160*80	160	80	96	13	83	155	76	30	155.5	30

X. Communication protocol

1. Please refer to “General MODBUS-RTU Communication Protocol for Counter, Timer, Frequency Meter”, this protocol can be acquired through our salesperson or downloaded from our official website www.toky.com.cn.

XI. Notes

- In measuring status, externally connect RST terminal or manually press RST key, will reset timing value, counting value and output.
- When counter input mode is Mode d, it can match with rotary encoder, and it doesn't connect with pull-up resistor any more. (Only for NPN)
- After changing meter's working mode, please press “RST” key to reset the meter, then it can measure and control reliably.
- If meter displays “Error” or “Erro”, please check if parameter PS1, PS2 & SCL accord with logic relation or not. (Logic relation refers to sheet 2)
- If there is no standard frequency signal, please don't use frequency calibration menu.
- Input signal: the distance between sensor and counter should be as short as possible; if need to prolong the signal line, the shielded line should be used; signal line and power line should be seperated.
- Counter input connection: when in highspeed mode(1K, 5K, 10K), if you use connecting point input mode, it may count too much; so the connecting input mode should be set as low speed input (1 or 30pcs).
- Can't be used at places as below: the place of serious vibration and impact; the place of strong acid and alkali; place in direct sunlight; place with strong magnetic field and electronic interference.
- Mounting environment: it should be used indoor; altitude less than 2000M; pollution grade is 2.

※If the above operations are not followed, it may cause product failure.