

CI Series Multi-function Counter User Manual



Features:

- ⊙ Counting Speed can reach 10KCPS
- ⊙ Free Setting Ratio 0.00001 ~ 999999
- ⊙ Universal Input, Choose NPN or PNP input through Software
- ⊙ Up to two Counting / Length Counting alarm output, one Batch Counting alarm output;
- ⊙ Applicable to Light Industries, Machinery, Packing, Food industries, etc. for control of Length and counting etc

For your safty, please read following content carefully before you are using our Meter!

Safe Caution

- ※ Please read the manual carefully before you use the temperature controller.
- ※ Please comply with the below important points.
- ⚠ Warning An accident may happen if the operation does not comply with the instruction.
- ⚠ Notice An operation that does not comply with the instruction may lead to product damage.
- ※ The instruction of the symbol in the manual is as below.
- ⚠ An accident danger may happen in a special condition.

⚠ Warning

1. A safty protection equipment must be installed or please contact with us for the relative information if the product is used under the circumstance such as nuclear control, medical treatment equipment, automobile, train, airplane, aviation and equipment etc. Otherwise, it may cause serious loss, fire or person injury.
2. A panel must be installed, otherwise it may cause creepage (leakage).
3. Do not touch wire connectors when the power is on, otherwise you may get an electric shock.
4. Do not dismantle or modify the product. If you have to do so, please contact with us first. Otherwise it may cause electric shock and fire.
5. Please check the connection number while you connect the power supply wire or input signal, otherwise it may cause fire.

⚠ Caution

1. This product cannot be used outdoors. Otherwise the working life of the product will become shorter, or an electric shock accident may happen.
2. When you connect wire to the power input connectors or signal input connectors, the moment of the No.20 AWG (0.50 mm²) screw tweaked to the connector is 0.74n.m - 0.9n.m. Otherwise the connectors may be damaged or get fire.
3. Please comply with the rated specification. Otherwise it may cause electric shock or fire, and damage the product.
4. Do not use water or oil base cleaner to clean the product. Otherwise it may cause electric shock or fire and damage the product.
5. This product should be avoid working under the circumstance that is flammable, explosive, moist, under sunshine, heat radiation and vibration. Otherwise it may cause explosion.
6. In this unit it must not have dust or deposit, otherwise it may cause fire or mechanical malfunction.
7. Do not use gasoline, chemical solvent to clean the cover of the product because such solvent can damage it. Please use some soft cloth with water or alcohol to clean the plastic cover.

1. Model Illustration

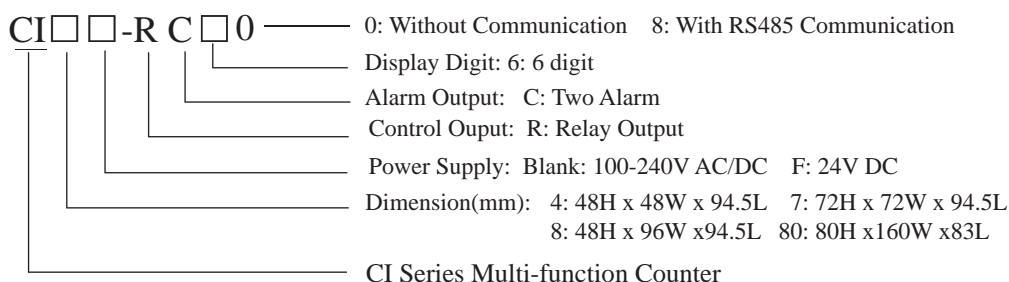

2. Model Type

No.	Model	Size (mm)	Output	Display Digit	Alarm Output	Batching Output	Communication
1	CI80-RC60	80H×160W	Relay Output	6	2	One Relay	NO
2	CI80-RC68	80H×160W	Relay Output	6	2	One Relay	RS485
3	CI8-RC60	48H×96W	Relay Output	6	2	One Relay	NO
4	CI8-RC68	48H×96W	Relay Output	6	2	One Relay	RS485
5	CI7-RC60	72Hx72W	Relay Output	6	2	One Relay	NO
6	CI7-RC68	72Hx72W	Relay Output	6	2	One Relay	RS485
7	CI4-RC60	48Hx48W	Relay Output	6	2	NO	NO
8	CI4-RC68	48Hx48W	Relay Output	6	2	NO	RS485

3. Technical Specification





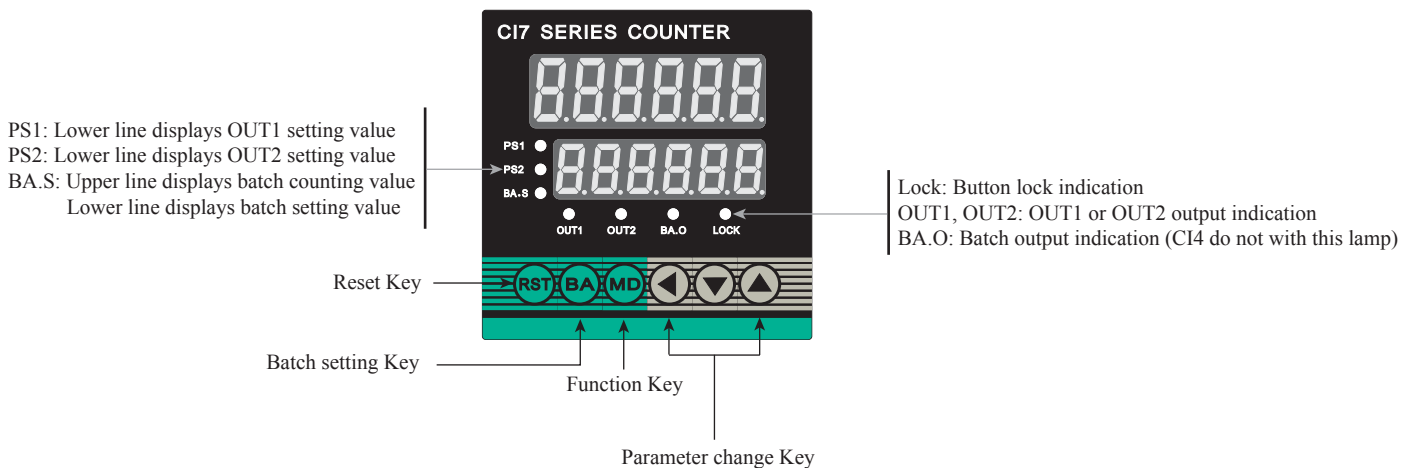







Series	CI	
Display	Dual Line 6 digit	
Power Supply	100-240V AC/DC	
Fluctuation range of Allowed Voltage	90~110% of Rated Voltage (AC Power)	
Input Frequency of INA, INB	1Hz、30Hz、1KHz、5KHz、10KHz can be choosed	
Width of Input Pulse	INA,INHIBIT,RESET,BATCH RESET,can choose 1ms or 20ms	
Input	Voltage Input: input impedance 5.4KΩ,“H”: 5~30VDC “L”:0~2VDC No-voltage Input: for Short-circuit impedance is 1KΩ, Residual Voltage: Max 2V DC, Open-circuit impedance Max 100KΩ	
One-shot Output	10/50/100/200/500/1000/2000/5000ms	
Control Output	Contact Capacity	NO:250VAC 3A Impedance NC: 250VAC 2A Impedance
	SSR Capacity	Max: 30VDC , Max: 100mA
Data Saving Time	10 Years	
Power of External Sensor	12VDC±10% Less than 100mA	
Ambient Temperature	-10℃~50℃ Unfreezing State	
Storage Temperature	-25℃~65℃ Unfreezing State	
Ambient Humidity	35-85%RH	
Dielectric Strength	Min: 100MΩ (at500VDC)	
Dielectric	2000V AC 50/60Hz one minute	
Interference (AC Power)	±2kV Square-wave generator interference (width of pulse: 1us)	
Vibrate	Mechanical	Amplitude:0.75mm Frequency: 10-55Hz X,Y,Z each direction for one hour
	Fault	Amplitude:0.5mm Frequency: 10-55Hz X,Y,Z each direction for ten minutes
Impact	Mechanical	300/S ² (about 30G) X,Y,Z each direction for three times
	Fault	100/S ² (about 10G) X,Y,Z each direction for three times
Using Life	Mechanical	more than 10,000,000 times
	Electrical	more than 100,000 times (NO: 250V AC 3A Load NC: 250V AC 2A Load)

4. Panel Indication



5. Operation Instruction

1. How to change counter setting value (Example: change the setting value from 175 to 180)

- (1)  Under Measuring Status, press  Key to enter into Setting Value modify status, Press  Key again to choose digit 5 and let it flicker
- (2)  Press  Key or  Key 5 times, change the digit from "5" to "0"
- 
- Under Measuring Status, press  Key to enter into Setting Value Modify Status, the flicking digit is from right to left circularly
- (3)  Press  Key again, choose digit "7" and let it flicker
- (4)  Press  Key for one time, change Digit "7" to "8", Press  Key for confirmation and return back to measuring status

6. Batch Counting and Batch Preset

1. Batch Counting Action

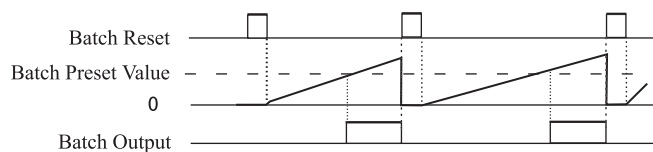

◆ Batch counting

Batch counting value counts up, it will not be reset unless external BATCH reset signal is applied.

When batch counting value counts over 999999, it will be reset to 0 and counts again.

Batch counting value is not reset by front  key or external reset signal.

(1) Batch counting in Counting mode.

Batch alarm outputs when counting alarm output quantity is equal to the batch setting value.

When batch control output is used, the time interval of counting up process is bigger than 10mS.

(2) Batch counting in Timing mode.

Batch alarm outputs when timing alarm output quantity is equal to the batch setting value.

In FLK output mode, the counting value of Batch counter is counting up, when Toff and Ton setting time passes.





◆ Batch output action

If batch output is ON, it will keep ON status until batch reset signal is applied.

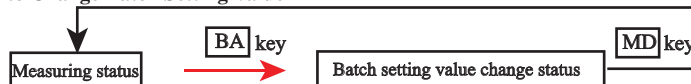
If batch output is ON, after power off and then power on again, batch output keeps ON status until external reset signal is applied.

2. How to Change Batch Setting Value



- ◆ In measuring status press  key to display batch setting value change status. The method for changing batch setting value is the same as the one for changing counting setting value. Press  key to select the digit to be changed to let it flicker, and then press   key to change the value. Press  key to confirm and menu returns to measuring status.

After changing the value, the upper LED will display the current batch counting value.

- ◆ When menu is batch setting value change status, if no button operation within 60 second, the menu will return to measuring status.

7. Application of Prescale Function

E.g.:Pulse number P is a number of pulse created by rotary encoder,L is the measured length,,

Prescale value is equal to L divides P.

- To use counter and rotary encoder to control length

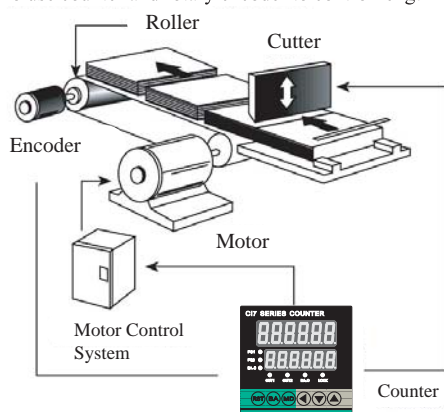

$$\text{Prescale Value} = \frac{\pi \times \text{Diameter of the Roller} (D)}{\text{PPR}}$$

$$= \frac{3.1416 \times 22}{1000}$$

$$= 0.069 \text{mm/pulse}$$

Set 0.069 of prescale value at prescale value set mode

The diameter of the roller connected to the rotary encoder is 22mm,
The PPR of the encoder is 1000

10. Active Model Exchange

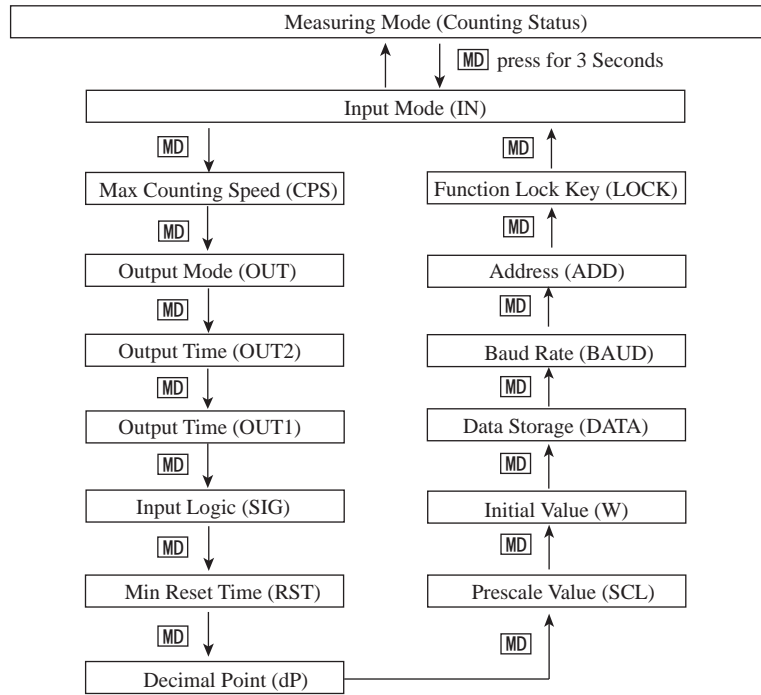

1. Under Function Setting Mode, if there is no any operation within 60 seconds, the counter will return back to normal measuring status
2. If you choose F or N output mode, when the counting value reached setting value, the output will be kept, there is no "OUT2 output time" menu in function setting mode.
3. If the output Mode is S, T and D, then input mode just can choose Ud-A, B, C. If the input mode want to choose UP/DOWN, then output mode just can choose other modes except S,T,D.
4. If the output mode choose D, when counting frequency over than 1Kcps, please choose SSR output.
5. When the Max counting speed is 5Kcps or 10Kcps, if change output mode to D, counting speed will automatically choose 1Kcps.
6. In the mode of function setting, the external input signal can be accepted, after exit, display value and output will be reset automatically.
7. Initial Value over than OUT1 and OUT2 setting value, OUT1 and OUT2 no output

11. Counter Meter Input Active Mode

※ A: More than Mim Signal Width B: More than half Mim Signal Width

Input Type	Illustration	Note
U (Add)		INA: Counting Input INB: Control Input INB=L; INA pulse input add count INB=H; INA forbid to count
		INA: Control Input INB: Counting Input INA=H; INB pulse input add count INA=L; INB forbid to count
D (Minus)		INA: Counting Input INB: Control Input INB=L; INA pulse input minus count INB=H; INA forbid to count
		INA: Control Input INB: Counting Input INA=H; INB pulse input minus count INA=L; INB forbid to count

Input Type	Illustration	Note
Ud-a (Add/ Minus-A) Order Input		INA: Counting Input INB: Control Input INB=L; INA pulse input add count INB=H; INA input pulse minus count
Ud-b (Add/Minus-B) Sole Input		INA input pulse, add count INB input pulse, minus count
Ud-c Phase Difference Input		INA before, INB add count INA delay, INB minus count Phase difference input (for rotary encoder)

When using rotary encoder's A, B phase output, please connect meter's INA, INB input terminal, and turn the input mode to Ud-C.

Symbol \ Input Type	Voltage Input (PNP)	Terminal Input (NPN)
H	5-30VDC	Short Circuit
L	0-2VDC	Open Circuit

13. Output Operation Mode For Counter

※ Initial Value $\bar{c} = 0$

	Input Mode			Operation after reached the setting
	Up	Down	Up/DownA, B, C	
F				Display will continue to increase or decrease, output will be kept to the reset input
N				Display and output will be kept to the reset input
C				Display value will return to the start status automatically, output delay will return to the initial status after reached the setting time. (Output activity is repeat single output)
R				Display value and output will automatically return to the initial status after keep to the delay setting time. (Output activity is repeat single output)

	Input Mode			Operation after reached the setting
	Up	Down	Up/DownA, B, C	
K				Display value will continue to increase or decrease until reset input, output delay will return to the initial status after reaching the setting time. (Output activity is repeat single output)
P				Display value kept to the delay time, will display the next cycle. (In the delay time, the next cycle counting and timing from initial status) (Output activity is repeat single output)
Q				Display value will continue to increase or decrease within output delay time, display value and output will return to the initial status after output delay reached the setting time. (Output activity is repeat single output)
A				Display value and OUT1 output will be kept to the reset input, OUT2 output will return to the initial status after reaching the setting time. (Output activity is repeat single output)

	Up/DownA, B, C	Operation
S		OUT1 and OUT2 meet following conditions, will keep ON status: Display Value ≥ Setting Value 1 Display Value ≥ Setting Value 2
T		When display value is smaller than the preset value "1", OUT1 keeps ON status When display value is smaller than the preset value "2", OUT2 keeps OFF status
D		When display value = setting value OUT1 and OUT2 keeps ON status When the speed of counter meter setting to 1kcp/s, should use SSR output

13. Connection Drawing

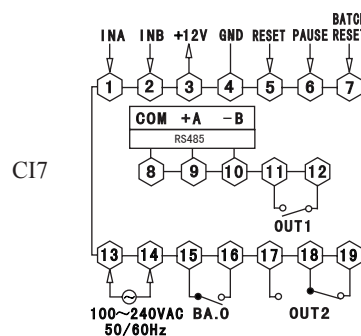
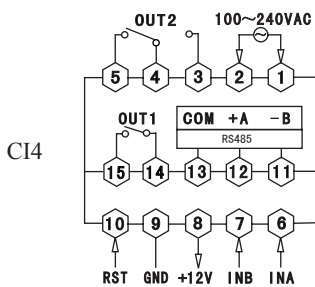

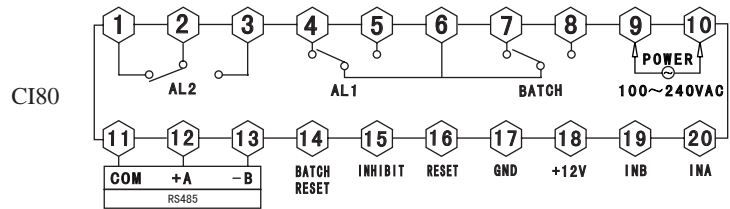
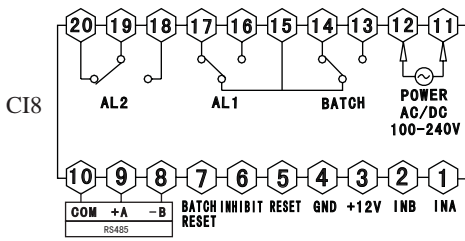

Note: If there is any change, please subject to the drawing on the meter!

14. Input Connection

1. Input logic: without voltage input (NPN)

(1). SSR input

Standard sensor: NPN output

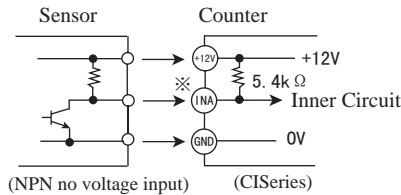

(2) Terminal Connection Counter

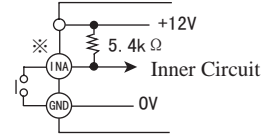

(CI Series)
Counting Speed: 1 or 30 cps setting (Counter)

2. Input logic : voltage input (PNP)

(1). SSR input

Standard sensor: NPN output

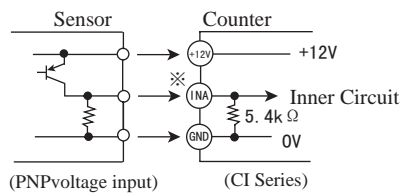

(2) Terminal Connection Counter

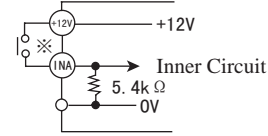

(CI Series)
Counting Speed: 1 or 30 cps setting (Counter)

15. Output Connection

Relay Output
Timer/Counter

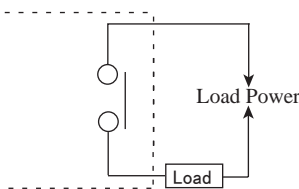

SSR Output
Timer/Counter

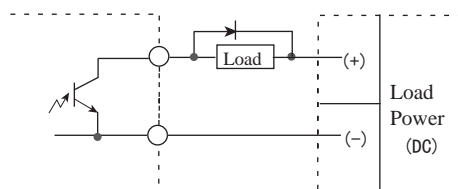

SSR Output:

1. Please use adaptable load and power, SSR output can not over then ON/OFF, capacity (30VDC, less than 100mA)
2. Making sure that the power connected in the right way,
3. When using Inductive load(Relay, etc), Filter circuit(Diode, etc) must connect to the load ends

16. Dimension

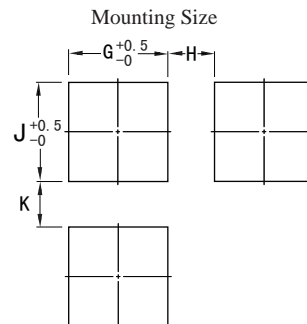
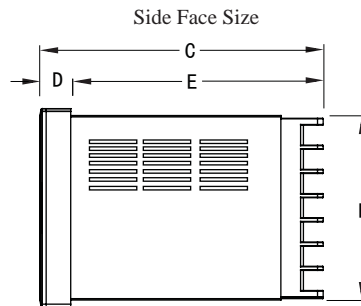
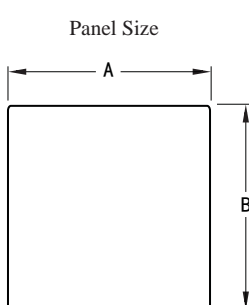

Model	A	B	C	D	E	F	G	H(Min)	J	K(Min)
CI4:(48*48)	48	48	97.5	3	94.5	45	45.5	25	45.5	25
CI7:(72*72)	72	72	97.5	3	94.5	67	67.5	25	67.5	25
CI8:(48*96)	96	48	97.5	3	94.5	44.5	90	25	45	25
CI80:(80*160)	160	80	96	13	83	155	76	30	155.5	30

Counter Meter Communication Protocol

1. Type and Format of Communication Data

This series counter meter are using asynchronous serial transmission communication interface, the TTL accompany to standard RS485 requirement. Communication compatible with standard Modbus RTU transmission, Start bit of frame data format is one bit, 8 data bit, un-checked, one stop bit. Baud rate of communication transmission data is 4800 or 9600 Bit/S which can set freely.

Frame Data Format

Start Bit	Data Bit	Checkout Bit	Stop Bit
1	8	No	1

2. Transmission Process of Communication Message

When the Communication order of Host computer be send to follow computer, the follow computer which with the same address of Host computer would accept this order. For example, when CRC check and order format are both without any question, then the follow computer will carry out this operation and send the result back to Host computer.

2-1 Meter Address (One Bit)

Meter address be included in the message's address zone, the range of address is 1-247. Host computer will choose the follow computer whose meter address can accompany to Host computer order's address zone. When the follow computer send back the result, it will put it's own meter address into the return-message's address zone, then that the Host computer can recognize which follow computer give reply. (Meter address is Unique)

2-2 Function Code (One Bit)

Function code be included into the function code zone. Host computer send function code, which can instruct the operation, to follow computers, When the follow computer make a reply, function code will tell the host computer whether there is anything wrong.

Function Code Definition

Function Code	Definition	Operation
0x03	Read Register	Read single or many register's data
0x10	Multi-write Register	Put numerous data into register

2-3 Data Area Which be included into the message's data zone, length of data will be different according to the function code.

3. Host Computer Order Format and Follow Computer Return Message Format

3-1 Multi-read Register

For Example: Host Computer send out read order, register data of follow computer OUT2 alarm value

Order format	Host Computer Send Out Order		
ADD Zone	Meter Address	0X01	
Function Zone	Function Code	0X03	
Data Zone	Start Register ADD	High Bit	0X00
		Low Bit	0X05
	Read Register Quantity	High Bit	0X00
		Low Bit	0X01
Error Check Zone	CRC Check Code	Low Bit	0X94
		High Bit	0X0B

Message Format	Follow Computer Return Message		
ADD Zone	Meter Address	0X01	
Function Zone	Function Code	0X03	
Data Zone	Data Bit Number		0X04
	OUT2 register data	Low Bit 1	0XC0
		Low Bit 2	0X5A
		High Bit 1	0XFB
		High Bit 2	0X34
Error Check Zone	CRC Check Code	Low Bit	0XA4
		High Bit	0XC7

Note: This is just an example for read single register data's order and return format, when it is need to read many registers at the same time, you just should know the register's start address and the number of read register. When return the data, low bit data will always before then high bit data.

3-2 Multi-write Register

For Example: Host computer send out order, write data 1000.000 into follow computer, register of OUT2 alarm value.

Order format	Host Computer Send Out Order		
ADD Zone	Meter Address		0X01
Function Zone	Function Code		0X10
Data Zone	Start Register ADD	High Bit	0X00
		Low Bit	0X05
	Write Register Quantity	High Bit	0X00
		Low Bit	0X01
	Write data bit		0X04
	Data which will be write into OUT2 register	Low Bit 1	0X40
		Low Bit 2	
		High Bit 1	0X0F
		High Bit 2	0X00
	Error Check Zone	CRC Check Code	Low Bit
High Bit			0X87

Message Format	Follow Computer Return Message		
Meter Address	ADD Zone		0X01
Function Code	Function Zone		0X10
Data Zone	Start Register ADD	High Bit	0X00
		Low Bit	0X05
	Write Register Quantity	High Bit	0X00
		Low Bit	0X01
Error Check Zone	CRC Check Code	Low Bit	0X11
		High Bit	0XC8

4. Communication Error Processing

When the meter check out the error which is not CRC check code error, then it will return error information to Host computer, Follow computer will return those information—function code high bit 1, meter address, error code—back to host computer.

4-1 Format of Error Code which be returned from Follow Computer

ADD Code	Function Code	Error Code	CRC Check Code Low Bit	CRC Check Code High Bit
One Bit	One Bit	One Bit	One Bit	One Bit

4-2 Error Code

0X01	Function Code Illegality	The meter didn't recognize the function code
0X02	Register Address Illegality	Receiving register address exceed the range of register's address
0X03	Register quantity Illegality	Receiving register quantity exceed the range of register's quantity
0X04	Data value Illegality	Receiving data value exceed the range of register's data value

5. Meter's Reference Address

No.	Register ADD	Register Name	Data Type	Measuring Range	Nature	Note
0	0x0001	Value PV	long	-----	R	Reserve 3 decimal point
1	0x0002	Batch Value BV	Unsigned long	-----	R	
2	0x0003	Alarm Status	Unsigned long	-----	R	
3	0x0004	OUT1 Alarm (PS1)	Unsigned long	1~999999000	R/W	Reserve 3 decimal point
4	0x0005	OUT2Alarm (PS2)	Unsigned long	1~999999000	R/W	Reserve 3 decimal point
5	0x0006	BA.Oalarm (BA.S)	Unsigned long	1~999999	R/W	
6	0x0007	Scale Factor SCL	Unsigned long	0.00001-9999.99	R/W	Reserve 5 decimal point
7	0x0008	Initial Value W	long	-99999-999999	R/W	Reserve 3 decimal point
8	0x0009	Meter's Status 1	Unsigned long	-----	R/W	
9	0x000A	Meter's Status 2	Unsigned long	-----	R/W	
10	0x000B	Meter's Status 3	Unsigned long	-----	R/W	
11	0x000C	Meter's Status 4	Unsigned long	-----	R/W	

* PV, PS1, PS2 will acquiesce in 3 decimal point. Actual data=return data or write in data/1000. If Read PV register return data=1, the the actual PV value=0.001. At the same time, when write 1000000 into PS2 register, then the actual OUT2setting value (PS2)=1000.0000.

6. Alarm Status (Add:0x0003)

Bit31	Bit30	Bit29	Bit28	Bit27	Bit26	Bit25	Bit24	Bit23	Bit22	Bit21	Bit20	Bit19	Bit18	Bit17	Bit16
Reserve								BA.O Alarm Output Symbol							
Bit15	Bit14	Bit13	Bit12	Bit11	Bit10	Bit9	Bit8	Bit7	Bit6	Bit5	Bit4	Bit3	Bit2	Bit1	Bit0
OUT2 Alarm Output Symbol								OUT1 Alarm Output Symbol							

6-1、Bit0-Bit7 OUT1 Alarm Output Symbol: 0x00: OUT1 Alarm No Output, 0x01: OUT1 Alarm and Output.

6-2、Bit8-Bit15 OUT2 Alarm Output Symbol: 0x00: OUT2 Alarm No Output, 0x01: OUT2 Alarm and Output.

6-3、Bit16-Bit23 BA.O Alarm Output Symbol: 0x00: BA.O Alarm No Output, 0x01: BA.O Alarm and Output.

7. Register of Meter Status (Add: 0x0009)

Bit31	Bit30	Bit29	Bit28	Bit27	Bit26	Bit25	Bit24	Bit23	Bit22	Bit21	Bit20	Bit19	Bit18	Bit17	Bit16
OUT2 Output delay time setting menu								OUT1 Output delay time setting menu							
Bit15	Bit14	Bit13	Bit12	Bit11	Bit10	Bit9	Bit8	Bit7	Bit6	Bit5	Bit4	Bit3	Bit2	Bit1	Bit0
OUT Output type setting value								SIG Input terminal SSR choosing							

7-1、Bit0-Bit7: SIG Input terminal SSR choosing (choosing range: 0x00-0x01)。

Bit0-Bit7=0x00: NPN Input mode, Meter's signal input terminal will connect with 12V auxiliary power supply through inner 7.4K resistance.

Bit0-Bit7=0x01: PNPinput mode, Meter's signal input terminal will connect with public earth wire through inner 5.4K resistance.

7-2、Bit8-Bit15: OUT Meter's output mode choosing (Choosing range according to current status)。

Bit8—Bit15 Output mode							
Bit8—Bit15	Output mode	Bit8—Bit15	Output mode	Bit8—Bit15	Output mode	Bit8—Bit15	Output mode
0x00	F	0x01	N	0x02	C	0x03	R
0x04	K	0x05	P	0x06	Q	0x07	A
0x08	S	0x09	T	0x0a	D		

Note:Before you are changing the output mode to D , please sure that the count frequency CP≤1KHZ, otherwise it will return the error code!

7-3、Bit16—Bit31: OUT1、OUT2 Alarm Output delay time choosing menu (Choosing range 0x00-0x08).

Bit16—Bit23Corresponding OUT1output delay time			
Bit16—Bit23	Delay time	Bit16—Bit23	Delay time
0x00	10mS	0x01	50mS
0x02	100mS	0x03	200mS
0x04	500mS	0x05	1000mS
0x06	2000mS	0x07	5000mS
0x08	HOLD		

Note: Bit16—Bit23 choosing range (0-8)

Bit24—Bit31Corresponding OUT2output delay time			
Bit24—Bit31	Delay time	Bit24—Bit31	Delaytime
0x00	10mS	0x01	50mS
0x02	100mS	0x03	200mS
0x04	500mS	0x05	1000mS
0x06	2000mS	0x07	5000mS

Note :Bit24—Bit31Choosing range (0-7)

8. Register 2 of Meter Status (Add:0x000A)

Bit31	Bit30	Bit29	Bit28	Bit27	Bit26	Bit25	Bit24	Bit23	Bit22	Bit21	Bit20	Bit19	Bit18	Bit17	Bit16
In input Mode Choose								DATA Power OFF data preserve choose							
Bit15	Bit14	Bit13	Bit12	Bit11	Bit10	Bit9	Bit8	Bit7	Bit6	Bit5	Bit4	Bit3	Bit2	Bit1	Bit0
DPDecimal point display choose								RSTInput control signal valid length of pulse choose							

8-1、Bit0-Bit7: RST Input control signal valid length of pulse choose (Range 0x00-0x01)。

Bit0-Bit7=0x00: Input control signal valid length of pulse is 20mS。

Bit0-Bit7=0x01: Input control signal valid length of pulse is 1mS。

8-2、Bit8-Bit15: DPDecimal point display choose (Range 0x00-0x03)。

Bit8—Bit15	Decimal Point	Bit8—Bit15	Decimal Point	Bit8—Bit15	Decimal Point	Bit8—Bit15	Decimal Point
0x00	No Decimal Point	0x01	One Decimal Point	0x02	Two Decimal Point	0x03	Three Decimal Point

8-3、Bit16-Bit23: DATA Power OFF data preserve choose (Range 0x00-0x01)

Bit16-Bit23=0x00: Count comes to Zero when Power OFF.

Bit16-Bit23=0x01: Count value will be preserved when power off and will recount from this value from next time power on!

8-4、Bit24-Bit31: INInput mode choose (Range 0x00-0x04)。

Bit24—Bit31	Input Mode	Bit24—Bit31	Input Mode	Bit24—Bit31	Input Mode	Bit24—Bit31	Input Mode
0x00	U	0x01	D	0x02	UD-A	0x03	UD-B
0x04	UD-C						

9. Register 3 of Meter Status (Add:0x000B)

Bit31	Bit30	Bit29	Bit28	Bit27	Bit26	Bit25	Bit24	Bit23	Bit22	Bit21	Bit20	Bit19	Bit18	Bit17	Bit16
CPS Count Frequency UPPer limit Choose Menu								ADD Meter Communication ADD Setting Menu							
Bit15	Bit14	Bit13	Bit12	Bit11	Bit10	Bit9	Bit8	Bit7	Bit6	Bit5	Bit4	Bit3	Bit2	Bit1	Bit0
BAUD Communication Baud Rate Setting Menu								LOCK Button Level Setting Menu							

9-1、Bit0-Bit7: LOCK Button Level Setting Menu (Range0x00-0x03)。

Bit8—Bit15	Level	Bit8—Bit15	Level	Bit8—Bit15	Level	Bit8—Bit15	Level
0x00	L.OFF	0x01	LOC.1	0x02	LOC.2	0x03	LOC.3

9-2、Bit8-Bit15: BAUD Communication Baud Rate Setting Menu (Range 0x00-0x01)。

Bit8-Bit15=0x00: Baud Rate=9600Bit/S (9600)。

Bit8-Bit15=0x01: Baud Rate=4800Bit/S (4800)。

9-3、Bit16-Bit23: ADD Meter Communication ADD Setting Menu (Range 0x01-0xf7)。

9-4、Bit24-Bit31: CPS Count Frequency UPPer limit Choose Menu (range decide by output mode)。

Bit24—Bit31	Frequency Uppper Limit	Bit24—Bit31	Frequency Uppper Limit	Bit24—Bit31	Frequency Uppper Limit	Bit24—Bit31	Frequency Uppper Limit
0x00	1HZ	0x01	30HZ	0x02	1KHZ	0x03	5KHZ
0x04	10KHZ						

Note: Output mode is D mode. Bit24-Bit31, choosing range (0x00—0x02), otherwise choosing range is (0x00—0x04)

10. Data Error Code

10-1. Data error code, under the condition of order format, meter address, function code and CRC check code are all correct, when the host computer write error data into the follow computer, follow computer will return back the error code which is in corresponding to the host computer, detail as follows:

Error Code	Definition	Error Code	Definition
0x14	OUT1 Alarm Value(PS1)Error	0x15	OUT2 Alarm Value(PS2)Error
0x16	BA.O Alarm Value (BA.S) Error	0x17	SCL Coefficient Error
0x18	W Initial Value Error	0x19	SIG Input Logic Choose Error
0x1A	OUT Output Mode Choose Error	0x1B	OUT1 Output Delay Time Choose Error
0x1C	OUT2 Output Delay Time Choose Error	0x1D	RST Min Reset time Choose Error
0x1E	DP Decimal Point Choose Error	0x1F	DATA Reserve Count Value Choose Error
0x20	IN Input Mode Choose Error	0x21	LOCK Button Choose Error
0x22	BAUD Communication Baud Rate Choose Error	0x23	ADD Meter Communication Address Setting Error
0x24	CPS Max. Count Speed Choose Error	0x25	
0x26		0x27	

Announcement:

When write the data into the meter through communication port, the write-in time of each storage element is limited, CI series counter meter can accept at least 100 thousand times write-in. If write-in time exceed than the provide, it can cause the damage on meter's storage element!